

AA

Miniature electropilots U1

Direct intervention electropilots with poppet valve system and cushioned bottom seals

- Assembly on sub-base
- Threaded connections on the body
- CNOMO interface
- Orientable coil (360°) separated from mechanical part
- Versions: 2/2 3/2 NC - NO
- Original Univer SPEED modular sub-bases



TECHNICAL FEATURES

Ambient temperature	-10 ÷ +50 °C			
Fluid temperature	max +95 °C			
Fluid	10 µm filtered air, lubricated or not, neutral gases (upon request other fluids can be used)			
Commutation system	direct intervention poppet valve system with cushioned seals			
Ways/Positions	2/2 NC, 3/2 NC, 3/2 NO^(a)			
Pressure	2/2, 3/2 NC = 0 ÷ 10 3/2 NO = 3 ÷ 10			
Control	electric			
Return	mechanical spring			
Connections	on sub-base or with threaded connections on the body			
	sub-base	G 1/8	M5	CNOMO
Nominal Ø (mm)	1,2 ÷ 1,5	1 ÷ 1,5	1 ÷ 1,5	1,2 ÷ 1,5
Nominal flow rate (NI/min)	30 ÷ 60	28 ÷ 60	30 ÷ 60	33 ÷ 45

CONSTRUCTIVE FEATURES

Materials see features below

ELECTRIC FEATURES

Series	U1	U3
Coil	DA	DC
Power consumption	3,5 W (DC) - 5 VA (AC)	2,5 W (DC) - 3,3 VA (AC)
Connector	AM 5110	AM 5111
Voltage	12 V DC - 24 V DC - 24 V AC - 110 V AC - 230 V AC	
Protection degree	IP65	

For other electric features see section "Accessories>Coils"

(a) = Mechanical part designed to keep the air supply always from the body
(Useful in case of assembly of more NC-NO pilots in series to have a unique supply port)

U1 Sleeves - with moving core



Material:	
sleeve	treated brass
cores and spring	stainless steel
seals	nitrile rubber

	Exhaust Ø mm	Pressure bar	Weight Kg	Part no.
3/2 NO	1,2	3÷10	0,030	AA-0150
3/2 NC	1,5	0÷10	0,030	AA-0157
2/2 NC	-	0÷10	0,030	AA-0170

Upon request viton seals and stainless steel sleeves (only NC versions)

■ NC

■ NO

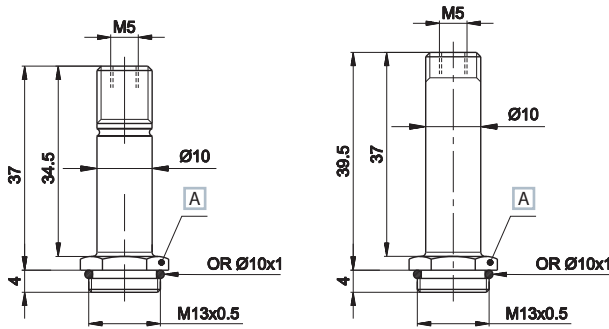

A Wrench 14

■ Particolare lavorazione sede

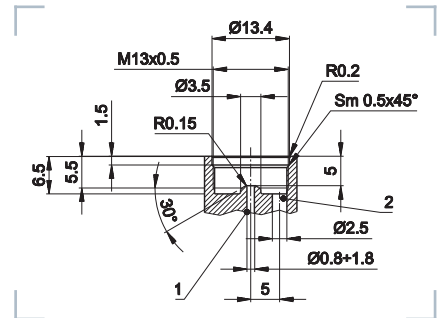

1 = Supply port
2 = Use

Locking rings for coils on sleeves



Version	Suitable for sleeves	Material	Coil	Part no.
1 = radial exhausts	3/2 NO	technopolymer	U1	AM-5213A
2 = radial exhausts	3/2 NC	technopolymer	U1	AM-5211A
3 = open exhausts	2/2 NC	brass	U1	AM-5211B

In order to convey exhausts, use version 3

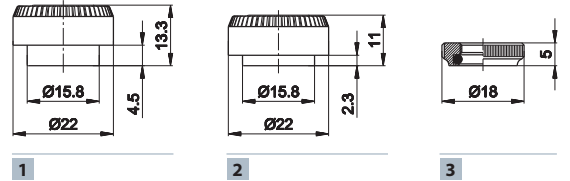

Standard manual overrides

Functionig	Suitable for sleeves	Symbol/Part no.
1 = with 2 position screw	all NC U1 electropilots that can use manual override	⊖
2 = with impulse 1-2 position screw	only CNOMO NC U1 electropilots	⊖
3 = with button with tool	only CNOMO NC U1 electropilots	→
4 = with button, 1 position	U1 3/2 NO electropilots	AM-5201 (a)

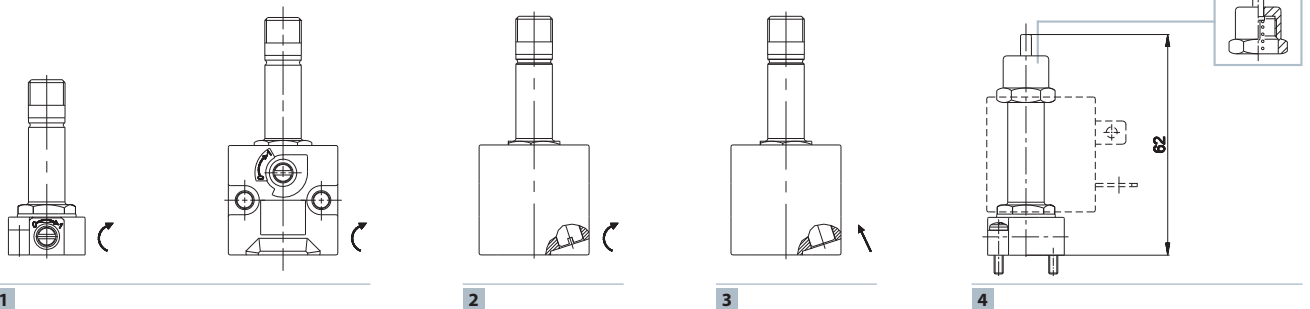

(a) = Mounted on the 3/2 NO sleeve

⊖ = with 2 position screw
→ = with button with tool

U1 2/2 - 3/2 Electropilot for assembling on sub-base



Material:
 valve body technopolymer
 sleeve treated brass
 core and spring stainless steel
 seals nitrile rubber

Weight (Kg): 0,036

Symbol	Ø (d) mm	Flow rate (NI/min)		Times (ms)		Manual override	Part no.
		1→2	2→3	En.	De-en.		
3/2 NC 	1,5	60	80	12	12	⊖	AA-0184
2/2 NC 	1,3	50	-	16	-	⊖	AA-0186
3/2 NO (b) 	1,2	30	70	11	10	(c)	AA-0188

Use SPEED subbase to build Manifolds, see following pages.
 Available upon request: brass valve body (without manual override), zamak valve body, stainless steel sleeve, other inner diameters.

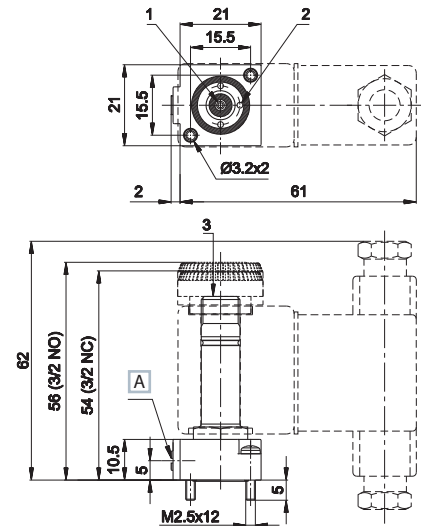

A Manual override 1 = Supply port
 2 = Use
 3 = Exhaust

U1 2/2 - 3/2 G1/8 Electropilot



Material:
 valve body brass
 sleeve treated brass
 core and spring stainless steel
 seals nitrile rubber

Weight (Kg): 0,105

Symbol	Ø (d) mm	Flow rate (NI/min)		Times (ms)		Manual override	Part no.
		1→2	2→3	En.	De-en.		
3/2 NC 	1,5	60	85	12	12	-	AA-0211
2/2 NC 	1,3	60	-	16	-	-	AA-0219
3/2 NO (b) 	1	28	75	11	9	(c)	AA-0213

Electropilot to be used done.
 Brass body suitable for use with non-aggressive liquids. No manual override.
 Available upon request: stainless steel sleeve - other inner diameters.

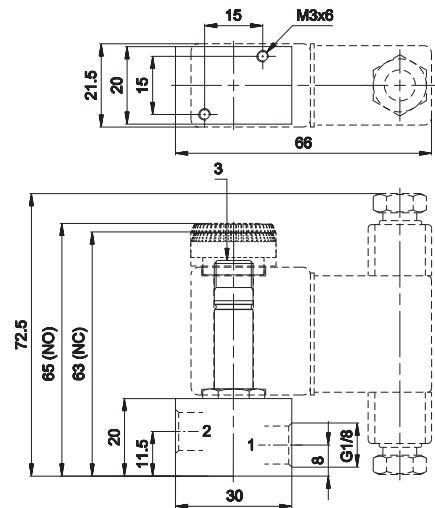

1 = Supply port
 2 = Use
 3 = Exhaust

U1 2/2 - 3/2 M5 Electropilot



Material:
 valve body brass
 sleeve treated brass
 core and spring stainless steel
 seals nitrile rubber

Weight (Kg): 0,065

Symbol	Ø (d) mm	Flow rate (NI/min)		Times (ms)		Manual override	Part no.
		1→2	2→3	En.	De-en.		
3/2 NC 	1,5	60	80	12	12	-	AA-0231
2/2 NC 	1,3	50	-	16	-	-	AA-0239
3/2 NO (b) 	1	30	70	11	10	(c)	AA-0233

Electropilot to be used done.
 Brass body suitable for use with non-aggressive liquids. No manual override.
 Available upon request: stainless steel sleeve - other inner diameters.

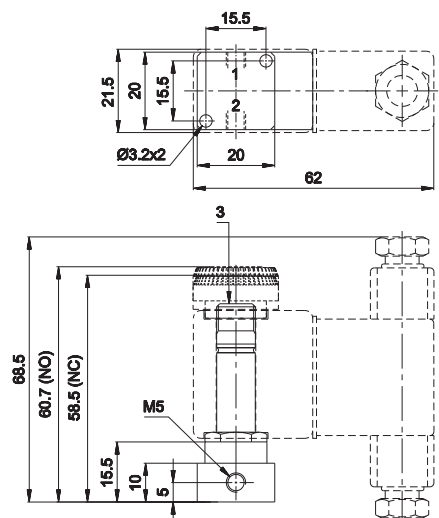

1 = Supply port
 2 = Use
 3 = Exhaust

(b) = close the exhaust of the 3/2 NO electropilot to get the 2/2 NO one
 (d) = the Ø shown on the 3/2 valves refers to the exhaust

(c) = manual override on AM-5201 ring nut

⊖ = with 2 position screw

Electropilots are supplied without coil, connector and locking ring

U1 CNOMO 2/2 - 3/2 Electropilot for mounting on sub-bases SPEED U2



Material:
 valve body technopolymer
 sleeve treated brass
 core and spring stainless steel
 seals nitrile rubber

Weight (Kg): 0,155

Symbol	Ø (d) mm	Flow rate (NI/min)		Times (ms)		Manual override	Part no.
		1→2	2→3	En.	De-en.		
	1,5	45	77	12	12	⊖	AA-0400
	1,5	45	77	12	12	→	AA-0400U
	1,3	42	-	-	-	⊖	AA-0402
	1,2	33	77	11	10	(c)	AA-0404

Sub-base: SPEED U2. Available upon request: brass valve body (without manual override). Zamak valve body. Stainless steel sleeve - other inner diameters.

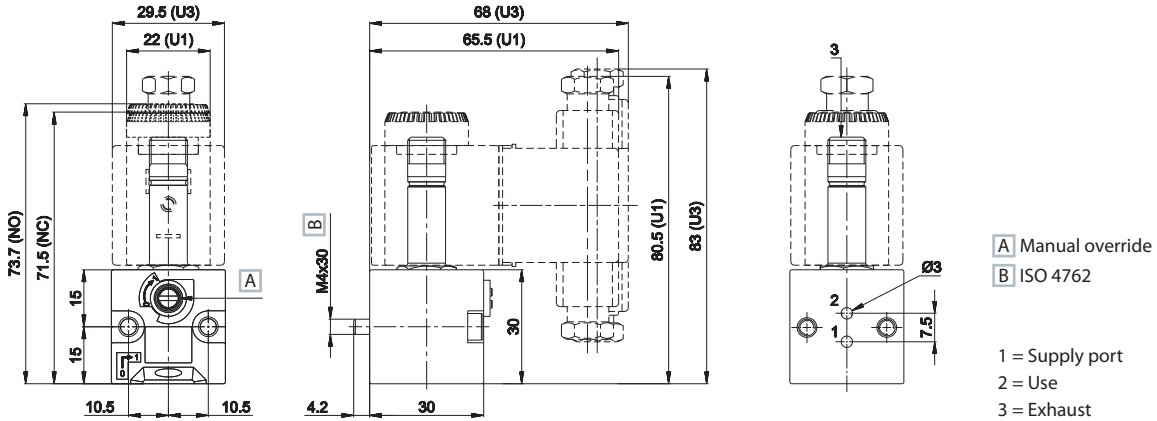

Modular sub-base "SPEED" series U1/U2 G1/8



Electropilot	Connections	Material	Weight Kg	Part no.
U1 for base	G 1/8	zamak	0,037	AA-0450
U2 for base	G 1/8	zamak	0,075	AB-0900

Advantages

The original UNIVER "Speed" series was designed to solve some operational problems

- Possibility of defining the number of sub-bases at the moment of use
- Possibility of freely increasing or reducing the number of elements
- Quick assembly with special screw (built-in) standard supplied
- Reduction of stock holding
- Easy technical intervention

Air supply is rotated by 90° in comparison with side consumption
 Standard (built-in) screw and O-Ring

When assembling the manifold, put the bases on a flat surface and tighten the screw until the manifold is perfectly aligned.

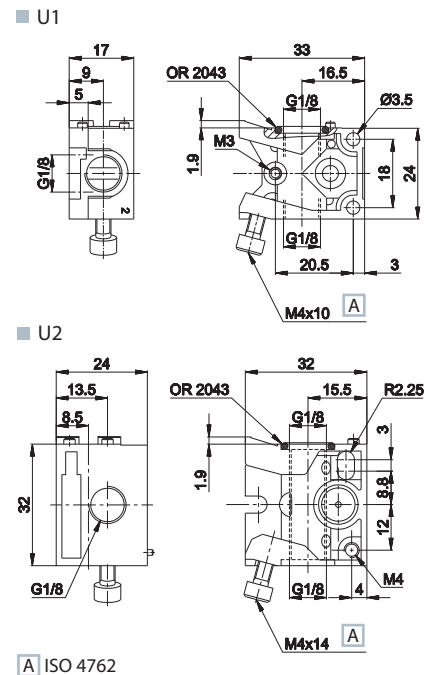

- (b) = close the exhaust of the 3/2 NO electropilot to get the 2/2 NO one
- (d) = the Ø shown on the 3/2 valves refers to the exhaust
- (c) = manual override on ring nut AM-5201
- ⊖ = with 2 position screw
- = with button with tool

U1 G1/8 sub-base

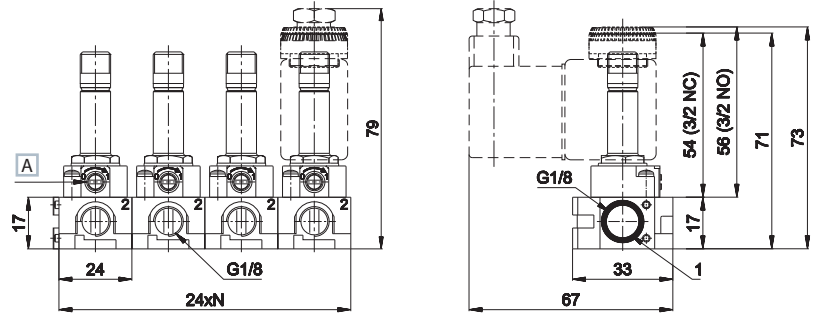

A Manual override

1 = Supply port
2 = Use

N = Number of valve positions

U2 G1/8 CNOMO sub-base

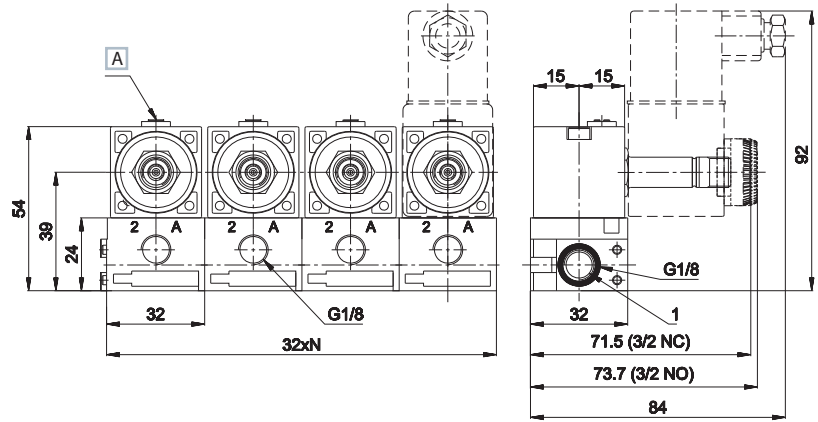

A Manual override

1 = Supply port
2 - A = Use

N = Number of valve positions

